

MICRO GRIP 1 mm / 2 mm

INSTRUCTION MANUAL

MICRO GRIP TYPES AND SPECIFICATIONS



| Max. load in kg | Micro Grip 1 mm | Micro Grip 2 mm | Micro Grip Lock 2 mm |
|------------------------|-----------------|-----------------|----------------------|
| Artiteq 1 mm perlon | 5 kg | x | x |
| Artiteq 1 mm steelwire | 10 kg | x | x |
| Artiteq 2 mm perlon | x | 20 kg | 20 kg |
| Artiteq 2 mm steelwire | x | 20 kg | 20 kg |
| Artiteq 2 mm rod white | x | 20 kg | 20 kg |

table 1

GENERAL SAFETY GUIDELINES

- » Do not exceed the maximum loads shown in table 1.
- » Only fit the Micro Grip to Artiteq cables/rods as shown in table 1.
- » Only use the Micro Grip in interior spaces with a normal indoor climate (10 ... 40 °C , 40 ... 70 % relative humidity).
- » Do not expose the Micro Grip to chemicals/vapours such as solvents, chlorine fumes, steam, etc.
- » Do not use damaged Micro Grip fasteners.
- » Do not fit the Micro Grip to damaged cables/rods.
- » Regularly check the Micro Grip and the wire/rod for damage.
- » Stop using damaged products and replace them (see "Artiteq warranty and replacement").
- » Only use the Micro Grip for hanging frames/panels to a suspension system against wall.
- » Do not use the Micro Grip above areas where people may be located (e.g. freely hanging in a room or above a passageway).
- » When making adjustments, remove the frame from the Micro Grip or support it so that no weight is hanging on the Micro Grip.
- » Never press the control button if there is weight hanging on the Micro Grip.
- » Always leave at least 5 cm of cable/rod protruding under the fastener.

MICRO GRIP DESCRIPTION

The Micro Grip is an adjustable fastener that can be used to hang frames/panels onto a suspension system on the wall. The clamping mechanism is self-clamping. Clamping increases in force with higher loads. Unlocking the clamping mechanism allows the Micro Grip to be vertically adjusted on the cable/rod. The Lock type allows the concealment of the cable behind the frame to protect against unintentional unhooking.

MOUNTING AND USE OF THE MICRO GRIP

The frame/panel can be hung from one or two cables: one centrally placed Micro Grip behind the frame or maximum two Micro Grip fasteners, one on each side (both an equal distance from the middle of the frame). Frames are more stable when hanging from two cables (particularly large frames). The cables/rods must be vertical.

Fitting the Micro Grip to the cable/rod:

- » Only fit the Micro Grip to Artiteq cables/rods as shown in table 1.
- » Pinch the control button and the fastener's housing together.
- » Insert the cable/rod into the top of the Micro Grip until approximately 5 cm of cable/rod protrudes under the fastener.

Setting the Micro Grip to the correct height:

- » Always leave at least 5 cm of cable/rod protruding under the fastener.
- » When making adjustments, remove the frame from the Micro Grip or support it so that no weight is hanging on the Micro Grip.
- » Never press the control button if there is weight hanging on the Micro Grip.
- » Pinch the control button and the fastener's housing together.
- » Slide the fastener to the desired height.

Hanging a frame/panel to the Micro Grip

- » Hang the frame on the Micro Grip using the cable on the back of the frame or the designated eyes.
- » Do not use any sharp objects to fasten the frame to the Micro Grip.
- » Use only eyes/cables with a maximum diameter/thickness of 2 mm for the Micro Grip 1 mm and maximum 3 mm for the Micro Grip (Lock).

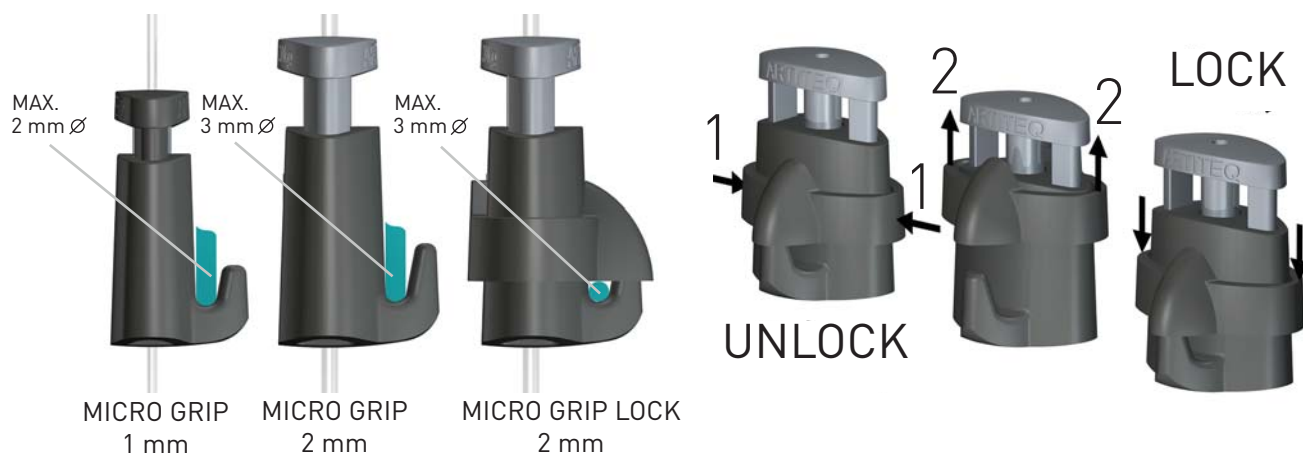

ARTITEQ WARRANTY AND REPLACEMENT

Artiteq offers a 10 year warranty on the Micro Grip and the cables/rods to which they are fitted. In case of damage/wear and tear resulting from normal use during this period, Artiteq will replace the product at no extra cost. If a product is no longer available, it will be replaced with an equivalent product. Send the damaged products along with a brief description and/or photos of how the product is/was used, your address and proof of purchase to: Artiteq, Herastraat 39, 5047 TX Tilburg, The Netherlands, Email info@artiteq.com.



Together with TÜV Nederland, Artiteq has established procedures for the protection of the quality of the Micro Grip 1 mm and 2 mm. The implementation of these procedures is supervised by TÜV Nederland.